

WDM Technologies on Military Platforms:

**Where are we going and
how should we get there?**

Floyd A. Fazi, Jr.
Lockheed Martin Aeronautics Company

APPROVED FOR PUBLIC RELEASE, DISTRIBUTION UNLIMITED

REVIEW OF THIS MATERIAL DOES NOT IMPLY DEPARTMENT OF
DEFENSE INDORSEMENT OF FACTUAL ACCURACY OR OPINION

Topics of Discussion

- **Technology availability, maturation, and development**
- **LM Vision of the future (military operational capabilities and platform missions)**
- **Standardization/Inter-Operability**

WDM on Military Platforms



**Multiple programs will and are benefiting from
WDM technology development**

Commercial Market and Products

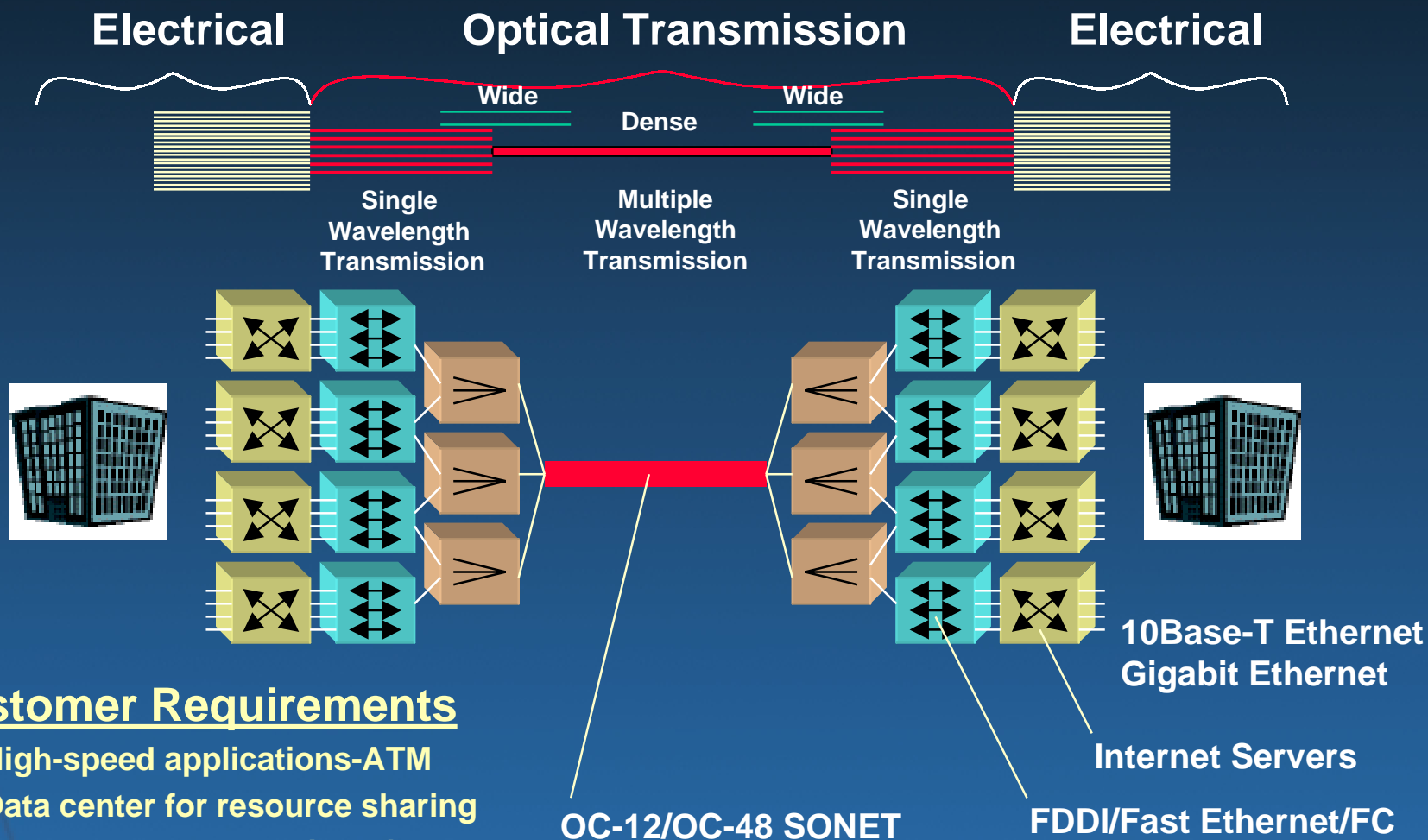

Customer Requirements

- High-speed applications-ATM
- Data center for resource sharing
- Storage area networking-Fibre Channel
- LAN backbones
- Video and others

Current LM Military Demonstrations

FAST Avionics Bus Demonstration

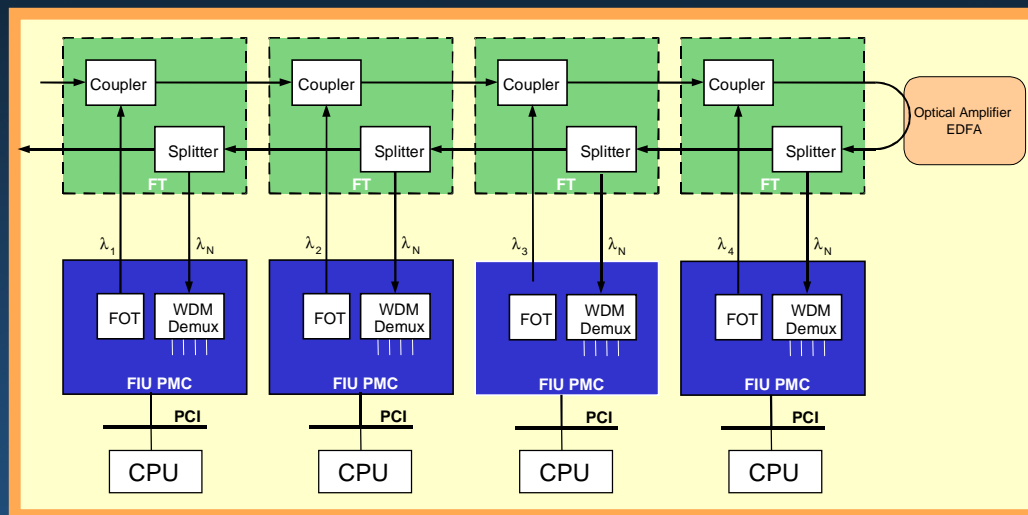

FOBWDM™ Demonstration

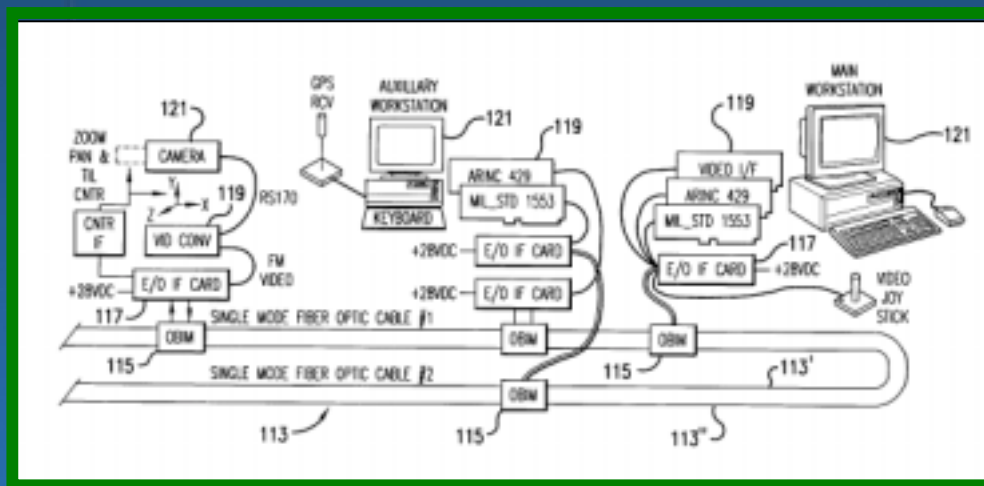

Example of Bus Interface

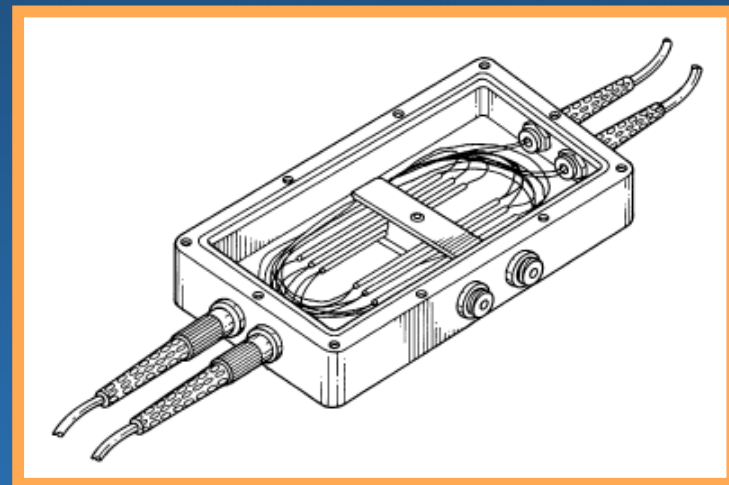

US Patents 5,898,801 & 5,901,260

REVIEW OF THIS MATERIAL DOES NOT IMPLY DEPARTMENT OF DEFENSE
INDORSEMENT OF FACTUAL ACCURACY OR OPINION

RF4

06C3200021

Future Uses of WDM in Air and Space

VMS and Health Management

- Sensors
- Data Links
- Pilot Interface

Avionics

- Sensors
- Communication Links
- Phased Array Antennas

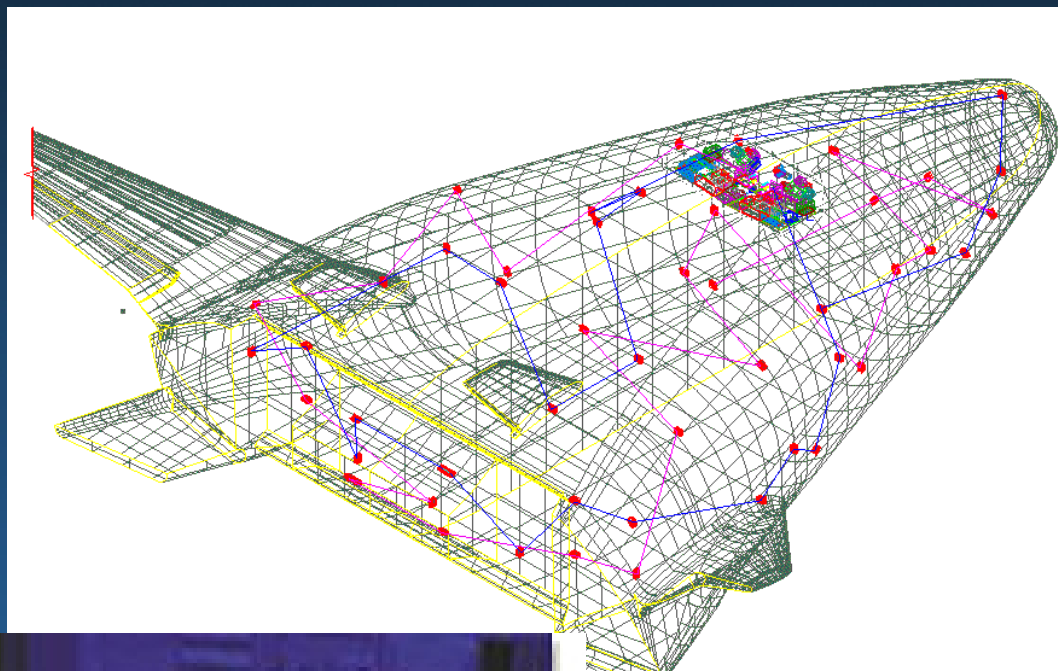

Naval & Satellite Uses for WDM

Naval

- Ship Board Systems
- Communications
- Sensors
- Towed Arrays

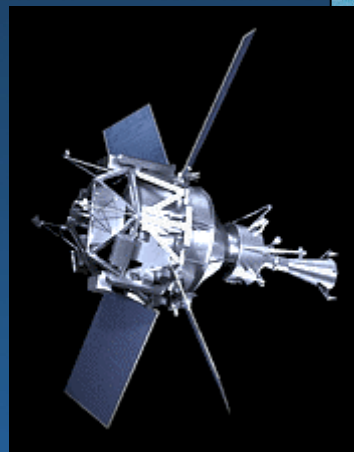

Satellite

- Signal Distribution
- Phased array beamformers
- Processing



Standardization & Inter-Operability Issues

International Telecommunications Union (ITU):

- ! Point-to-point systems are deployed in “open” architectures**
- ! “Grid” specifies a 1,550 wavelength band at 100GHz frequency spacing**
- ! Industry products conform to the grid therefore elements are standardized/interoperable**

Commercial WDM Solution:

- ! WDM is a proven method for low-cost increased bandwidth**
- ! Increasing bandwidth by a factor of 30, with 50% cost reduction**
- ! Large volumes of point-to-point WDM systems have been deployed to increase capacity of existing fiber cable plants**

Optical Transmission Formats:

Single Wavelength Transmission

# Serialized Data Streams	1 per wavelength
Multimode Fiber Availability	Yes
Singlemode Fiber Availability	Yes
COTS Components	850nm, 1300nm, 1550nm
Cost Target	\$100 per transceiver

Optical Transmission Formats:

Multiple Wavelength Transmission

	Wavelength Division Multiplexing	Dense Wavelength Division Multiplexing
# Serialized Data Streams	2 to 8	8 to 128
Multimode Fiber Availability	Yes	No
Singlemode Fiber Availability	Yes	Yes
COTS Components	850nm, 1300nm, 1550nm	1550nm
Comment	Wide wavelength separation increases system reliability	Small wavelength separation requires precision laser temperature control
Cost Target	<\$200 per multichannel transceiver	\$1K per multichannel transceiver

How Do We Get There

- **Transition COTS Components into Military Environments**
- **Demonstrate WDM Components Enabling WDM Technologies on Military Platform**
- **Continue and Expand Research Efforts**
- **Transition LM Research into COTS products**